

COA031: Broadband Transmission Technology, 2026
Department of Communication Engineering, NCU
Homework #3

Prof. *Dah-Chung Chang*
 Date: 2026/5/6, Deadline: 2026/5/27

Consider the following four transceiver architectures that 64-QAM symbols are transmitted on Rayleigh fading channels.

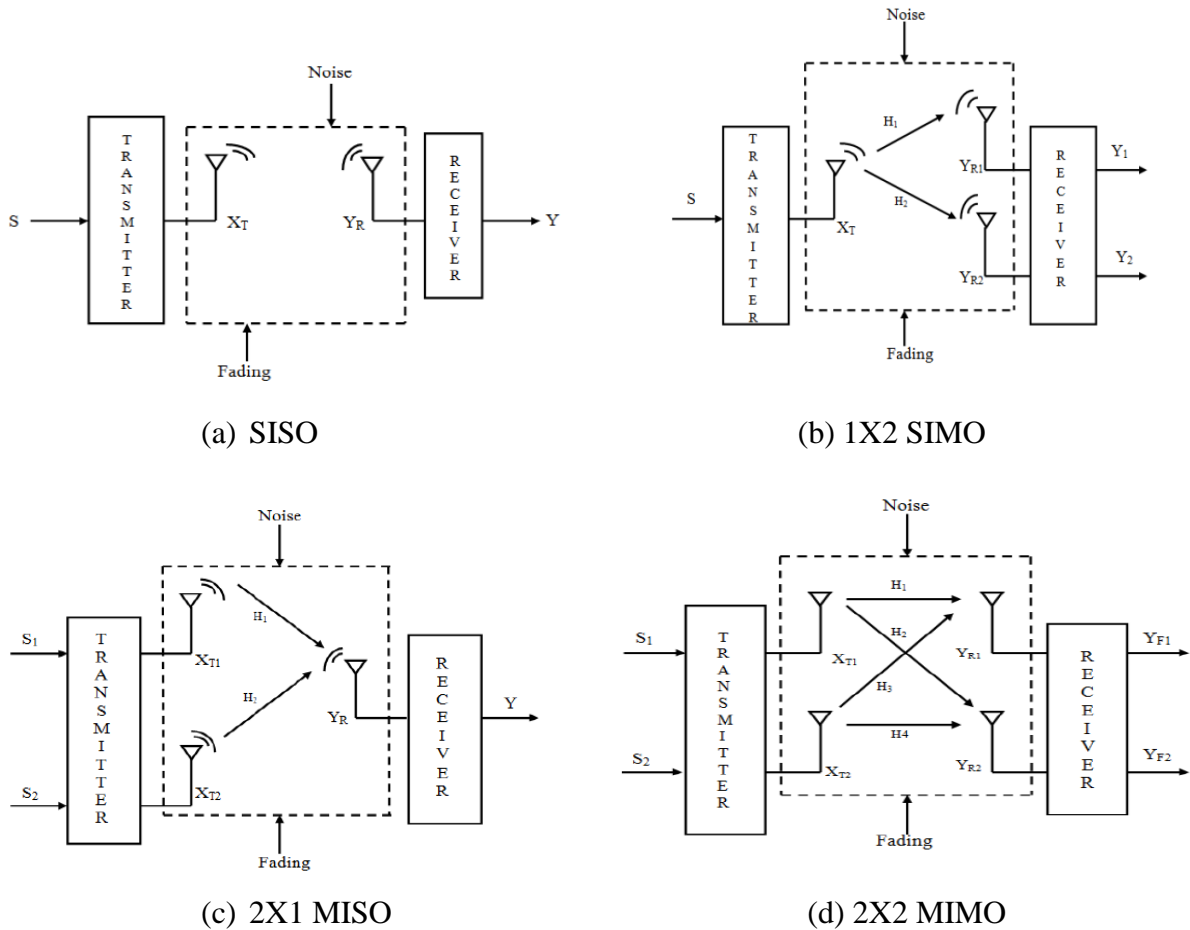

Suppose that the power of the 64-QAM signals is normalized as unit with factor $1/\sqrt{42}$, the channels are modeled as Rayleigh fading with $h_{pq} \sim N(0,0.5) + jN(0,0.5)$ for $p, q \in \{1, 2\}$, and the SNR is 30 dB. Assume that the channels are frequency flat and slowly varying such that fading is constant across two consecutive symbols. The precoding method at the transmitter for 2X1 MISO and 2X2 MIMO uses the Alamouti 2X2 STBC matrix. Complete the above four receivers and show the received signal constellations for 50,000 transmitted 64-QAM symbols.

References: (SNR=30 dB)

